

SVR2

Parameters:

Power supply 7~18V DC, recommend 12~18V DCC

Decoder is supplied directly from DCC signal (line), it is highly recommended use signal booster. Power consumption is ca 300mA at running of servo (max is depended of type of servo and load), <70mA v at idle. Power consumption are at 15V DC.

Firmware is according to:

NMRA S-9.1/2006 – DCC electrical standard

NMRA S-9.2.1/2012-7 – DCC Extended Packet Formats

Heads up

During servo's movement, board not catching DCC signal due to accurate timing of servo's movement.

All settings, i.e. limits, DCC address, last position etc are stored in internal EEPROM and are stored even after power supply interruption.

LED1 is connected with relay K1 (connector X3) – when LED1 lit relay is switch to NO

LED2 is connected with relay K2 (connector X2) – when LED2 lit relay is switch to NO

After connection of power line (DCC) servo will move to last know limit position with delay calculate from DCC address. For example, board has address 2, servo will start moving 2 seconds after power up, next board has board for example address 4 so that servo will move 4 second after power up. This is important against to overload power supply at start-up.

Change position of servo

In case of received DCC address or short press button (<2sec) is changing position servo and change polarity.

At reach first servo's limit LED1 lit and LED2 switch off (only in case of set back indication).

At reach second servo's limit LED1 switch off and LED2 lit (only in case of set back indication).

Function relay 2, point 4c is useful for switch off supply to track/frog during movement of servo.

Settings

Enter to setting hold button pressed 3 seconds

For saving set adjustment and move to next setting step hold button 3 seconds, acknowledge with LED1 5x blink then LED1 and LED2 indicates setting step.

1. **First limit** (left from front view on servo's arm) – **LED1 ON, LED2 OFF**
With short presses to button correct position in steps 0,1°. Factory setting is middle position. Position edge is -80° from middle. When servo reach limit automatically turn back till second limit. When reach second limit turn again back. During setting is possible change direction with press button 1 second.
2. **Second limit** (right from front view on servo's arm) – **LED1 OFF, LED2 ON**
With short presses to button correct position in steps 0,1°. Factory setting is middle position. Position edge is +80° from middle. When servo reach limit automatically turn back till first limit. When reach first limit turn again back. During setting is possible change direction with press button 1 second.
3. **Moving speed** – **LED1 OFF, LED2 OFF** servo rotate from one limit to second cyclically.
With short pressing set desired speed, there is adjustable speed in 19 steps. Factory setting is at middle of range.
4. **Relay 2 function** – **LED1 5x blink, LED2 5x blink** then display setting according to following
 - a. **Back indication blinking** – blinking relay during servo's moving – Indicates LED1 – ON, LED2 – 6x blink, LED1 – stay ON
 - b. **Back indication switch over** – relay switch over after finish servo's moving – LED1 OFF, LED2 ON, LED1 ON, LED2 OFF, LED1 OFF, LED2 ON
 - c. **Switch on during movement** – relay switch on during servo's moving – LED1 – OFF, LED2 – 3x blink, LED1 – ON
5. **Moving style** – **LED2 5x blink, LED2 ON**
 - a. Continuous movement (suitable for train switch, doors, etc.) – LED1 ON
 - b. Middle stopping (suitable for semaphore – simulating stumble) – LED1 OFF

After finish of setting servo will run to previous position and board waits for DCC signal or pressing button.

Setting DCC address and command

For entering press and hold button 15 seconds.

1. Signalisation of DCC reading mode LED2 5x blink, LED1 5x blink, LED2 5x blink. Servo change position to "left" side, LED1 lit and board waiting for valid DCC address and command for first limit.
2. After reading valid address LED1 5x blink and LED1 stay lit.
3. For programming of "right" side press and hold button 3 seconds.
4. Servo change position to "right" side, LED2 lit and board now waiting for second command, heads up DCC address must be same with first limit. Only command must be different.
5. After reading valid address and command LED2 5x blink and LED2 stay lit.
6. For ending of programming press and hold button 3 seconds.

During setting could happen some trouble due to functionality of LENZE®, Z21®, DigiTrax® centrals. During setting switch of auto refresh DCC commands. Some of centrals are cyclically sending all known DCC addresses and their last command.

Factory setting

1. Press and hold button 15 seconds – LED2 5x blink, LED1 5x blink, LED2 5x blink
2. Again press and hold button 15 seconds – LED1 and LED2 5x together blink

Factory setting

First and second limit – middle position

Turning speed – middle speed

DCC address - 1

Position – first limit

Relay 2 function – back indication blinking

SVR2

Recommend installation of servo under train switch

Holder install always in right angle to direct track, this is prevent to overloading servo, switch and tracks. On pictures is right ideal position for installation. Manufacturer is not responsible for damage of servo, train switch, etc due to not correct installation.

Recommended shape for moving wire used for track switch

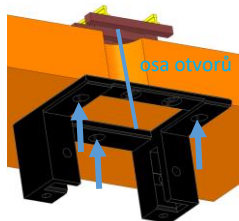

In place of passing through play wood board drill hole with diameter (this is valid for TT and thickness till 14mm). From bottom use at least two screw for fixing servo holder.

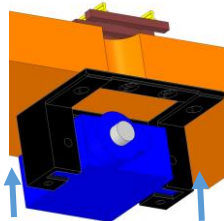

Press to position servo, you should hear little click.

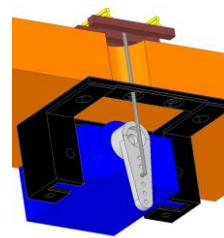

At the end put through wire via carrier arm, then through hole in holder and to track switch. Fix with screw to servo. Before place is recommend power up board with servo and not programmed limits. This step centre servo to middle point.

Electrical connection

Connectors:

X1 DCC connection or DC power supply with in depended polarity

X2 program able function of relay K2.

X3 switching polarity for frog:

For connectors X2 and X3 is same connection, both are galvanic protected (potential free)

1 – Normally close when LED not lit is connected this connector

2 – Common

3 – Normally open when LED lit is connected this connector

JP connector is for servo connection (colours are for supplied servo):

- - brown servo's wire (ground)

+ - Red servo's wire (power supply +5V)

S – yellow servo's wire (timing signal)

SL1 connection point (with small extra cost can be assembled with screw connector) can be used for external button (must be button not switch!). Left pad is active, right pad is common ground (common via rectifier bridge with using DC power supply and more boards for non DCC control). In case of usage without DCC, can be used boards with just one wire (left pad), control buttons on control panel can be commonly grounded.

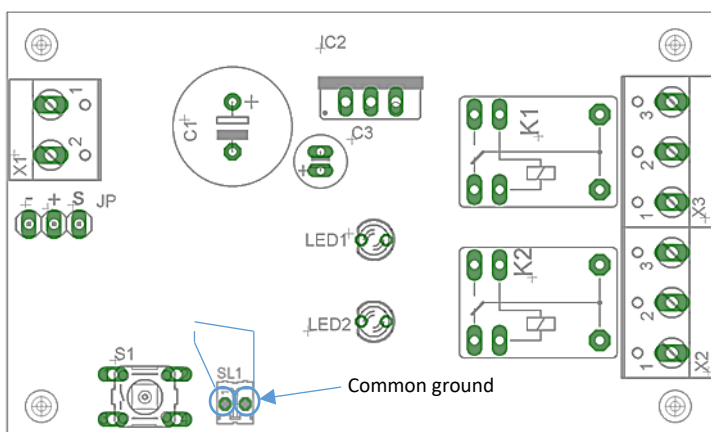

Connectors layout on board SVR v1.2



This symbol indicates that the equipment must not be disposed into the regular household waste stream, according to EU directive 2012/19/EU.